

# CTAE (hygienic version)

## HYGIENIC AIR HANDLING UNITS FOR HOSPITAL AND PHARMACEUTICAL SECTOR



### INTRODUCTION

**HYGIENIC** air handling unit suitable for applications in the hospital and pharmaceutical sector, or industrial applications where a high hygienic standard is required.

These units can be subjected to ordinary cleaning cycles in full compliance with all the construction measures necessary to facilitate proper cleaning and accessibility to all internal surfaces.

Another main feature is the reduction of thermal bridges.

The units are accompanied by CE certification and certification according to **VDI 6022**.

- AHUs with horizontal (H) or vertical (V) configuration.
- AHUs can be configured with a monobloc structure or divided into several modules to facilitate transport and facilitate the customer in handling and positioning it on site.
- All internal components are in stainless steel AISI 304 or AISI 316, designed to have no protrusions, sharp edges or corners in which dirt can accumulate.
- The internal corners are connected with a radius that allows easy cleaning and disinfection, as required by Directives 2006/42/EC and EN 6022.

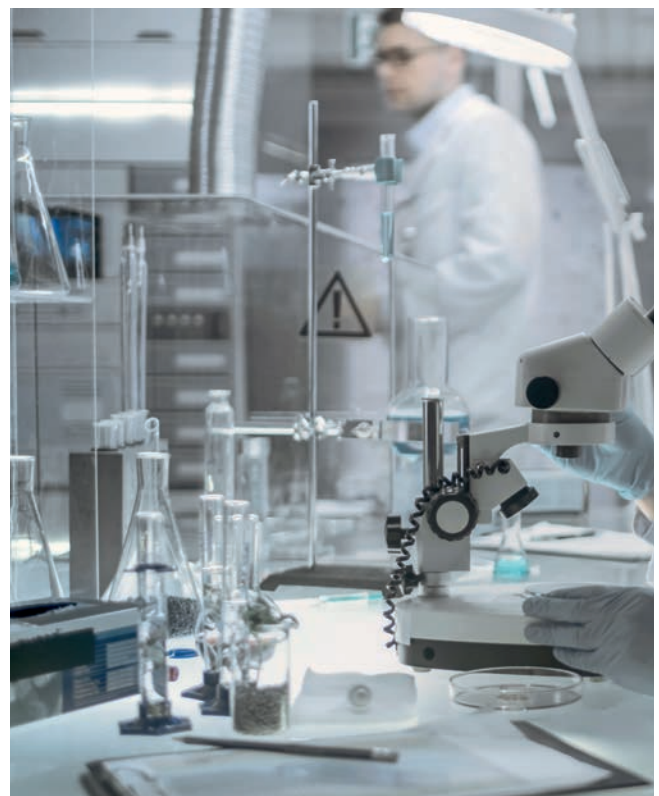

## CERTIFICATIONS

Good air quality means good quality of life. Certification in accordance with VDI 6022 ensures that the unit complies with the most stringent hygienic requirements in the industry. It also ensures that the supply air does not contain pathogenic spores or hazardous substances for the entire service life of the system, with a better indoor climate and optimal well-being and performance.

Materials certified according to VDI 6022 are subjected to extensive testing to ensure that they do not facilitate the growth of bacteria or fungi and are also tested for the release of hazardous substances.

Finally, these units are easy to clean because the surfaces are sealed and can withstand approved cleaning agents and disinfection methods.

This series has been designed specifically for applications in the hospital and pharmaceutical sector where a very high degree of cleanliness is required.



## MAIN CHARACTERISTICS

### STRUCTURE AND PANELS

- Frame made of anodized aluminium profiles with thermal break. Thickness: 60mm.
- Sandwich panels coupled by stainless steel screws to the anodised aluminium profiles.
- Sandwich panels, 63 mm thick, made with an internal shell in stainless steel AISI 304/316 with polyurethane foam in between, with a density of 40 kg/m<sup>3</sup> and external sheet metal of any sheet metal.
- Sloped drain pans in AISI 304 or AISI 316 on the treatment sections in order to avoid the stagnation of condensation or hygienic liquids. Their special construction with rounded edges ensures perfect drainage of hygienic liquids and the absence of condensation stagnation.



SLOPED DRAIN PANS

- Base frame in AISI 304/316 stainless steel of variable thickness and height to allow the creation of siphons of adequate height to the pressures at stake, with the possibility of adding feet adjustable in height.
- Inspection doors to allow disassembly and removal of all components.



INSPECTION SECTIONS



REMOVABLE SOUND ATTENUATORS

- Internal structural work in stainless steel AISI 304/316 designed and so built in order not to have protrusions, sharp edges or inaccessible corners in which dirt could accumulate.
- Internal corners connected with a radius that allows easy cleaning and disinfection, as required by Directive 2006/42/EC.
- Bottom sloped panels and drain valve in all sections without thermal treatment.
- Side removable sound attenuators for hygienic operations.
- Coils made of materials suitable for hygienic purposes (stainless steel) with a minimum spacing of 10 cm in order to insert indicators or adjustment instruments, positioned higher than the drain pan below to allow cleaning operations.
- Dampers with airtight gaskets in closed position (L4).

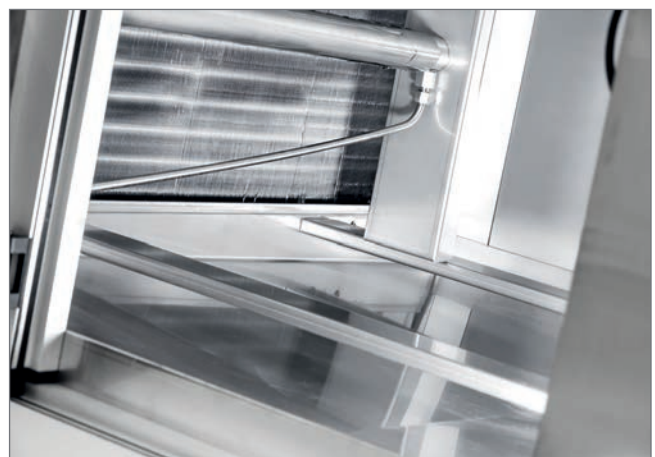

STAINLESS STEEL COMPONENTS

## CONFIGURATION AND TYPOLOGY

AHUs can be configured with a monobloc structure or divided into several sections to facilitate transport and facilitate the customer in handling and positioning on site, with horizontal (H) or vertical (V) configuration.

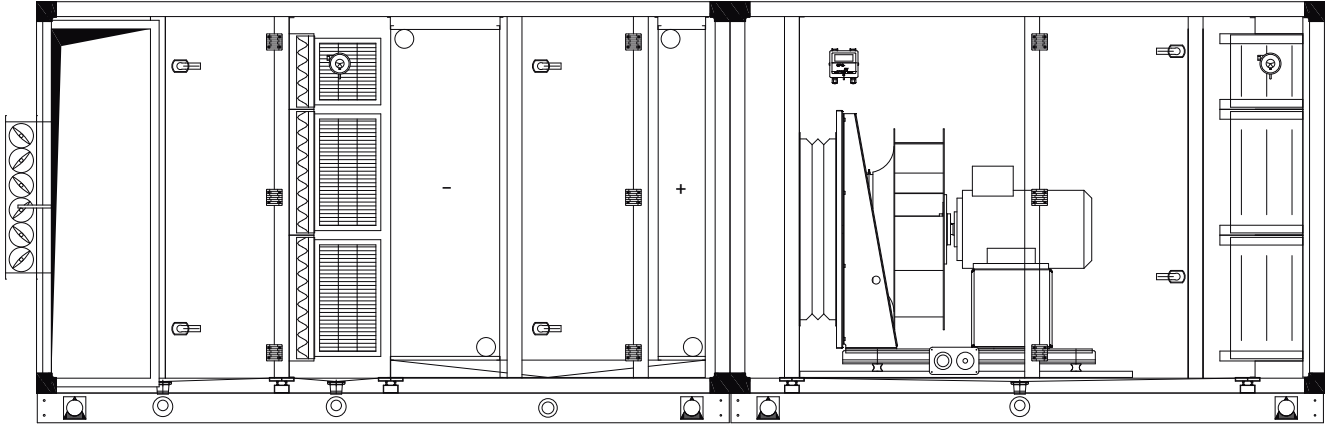

HORIZONTAL CONFIGURATION (H)

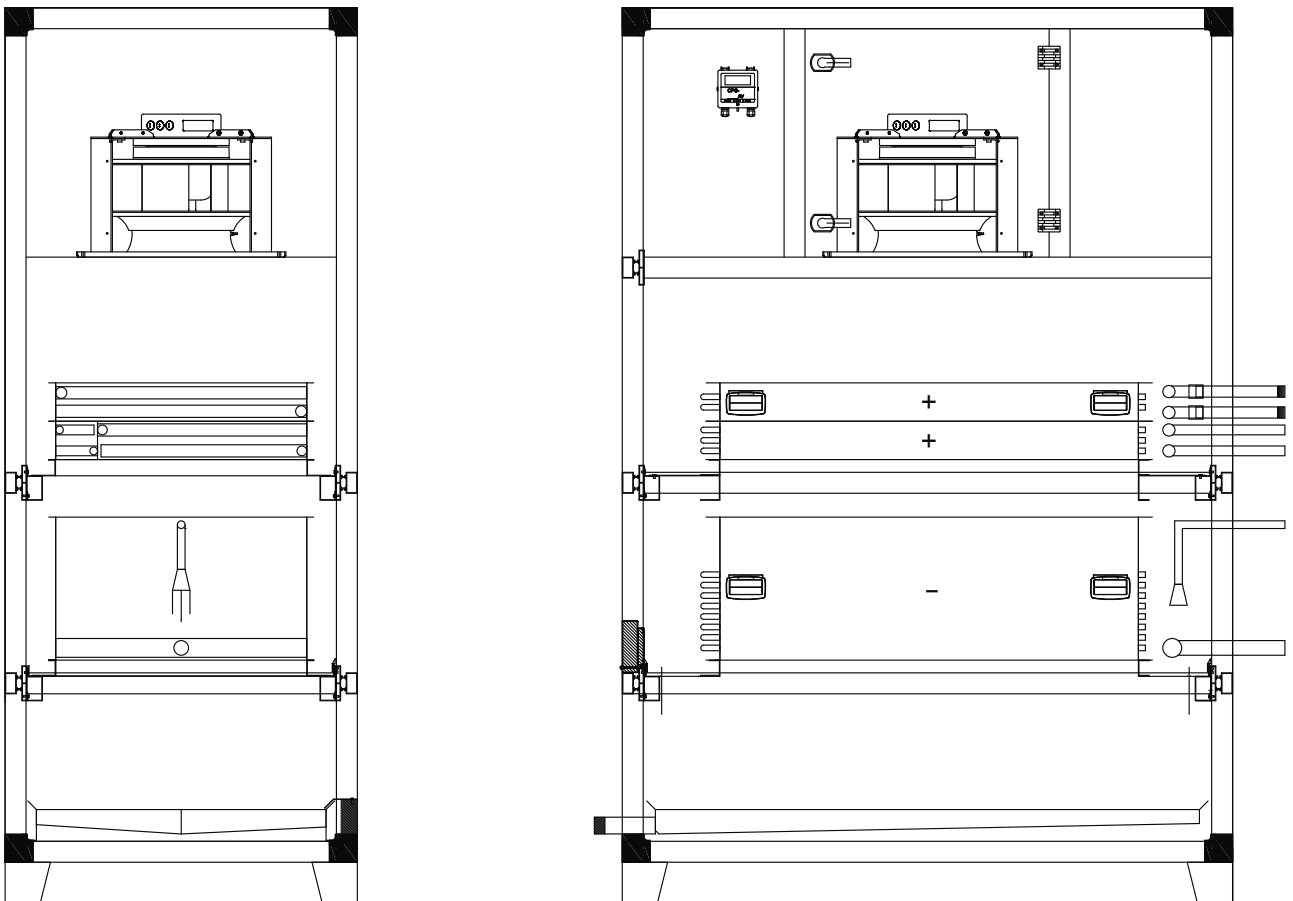

VERTICAL CONFIGURATION (V)